

COTTAGE HILL

Ayden



Elevation C



SIMPLY BUILT BETTER.

We are constantly improving our homes. Arden Homes reserves the right to revise and/or substitute Features, square footage, dimensions, specifications, architectural details, designs and pricing without notice.

Jordan Myrick
336-817-9305 | Jordan@theardengroup.com



COTTAGE HILL

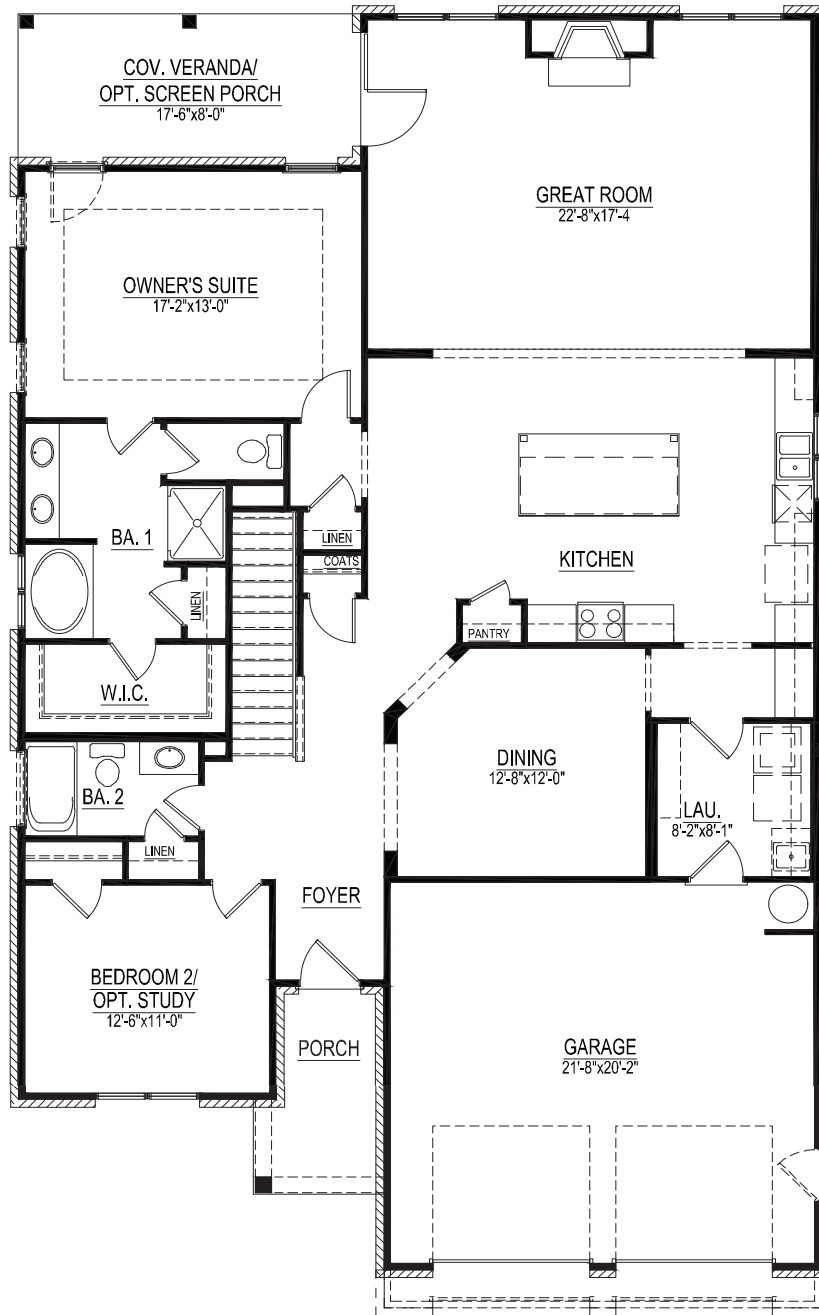

FIRST FLOOR PLAN



SIMPLY BUILT BETTER.

We are constantly improving our homes. Arden Homes reserves the right to revise and/or substitute Features, square footage, dimensions, specifications, architectural details, designs and pricing without notice.

Jordan Myrick
336-817-9305 | Jordan@theardengroup.com



COTTAGE HILL

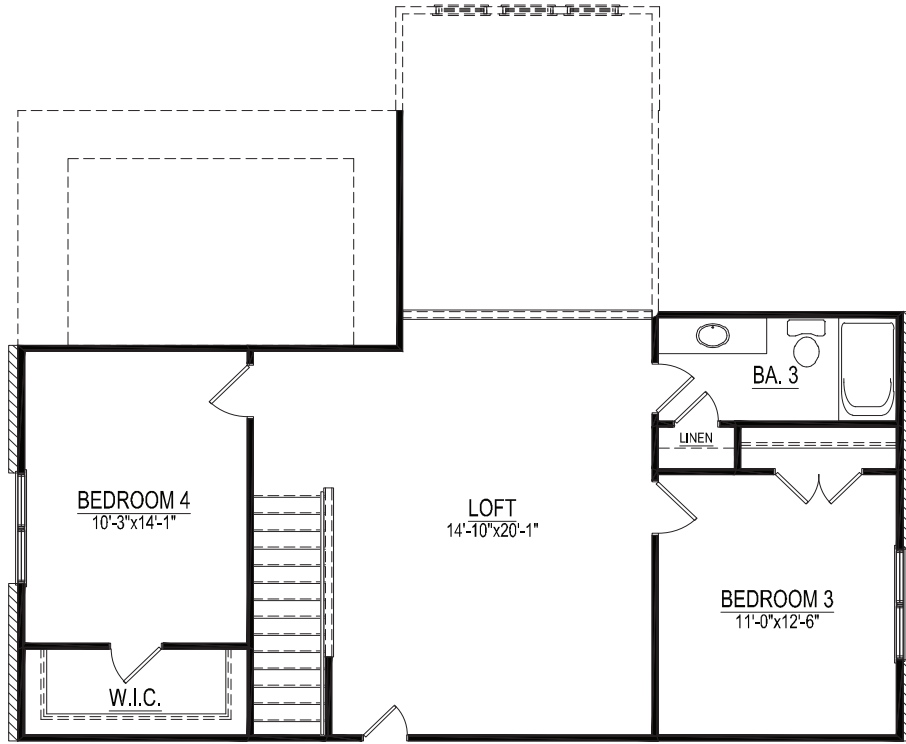

SECOND FLOOR PLAN

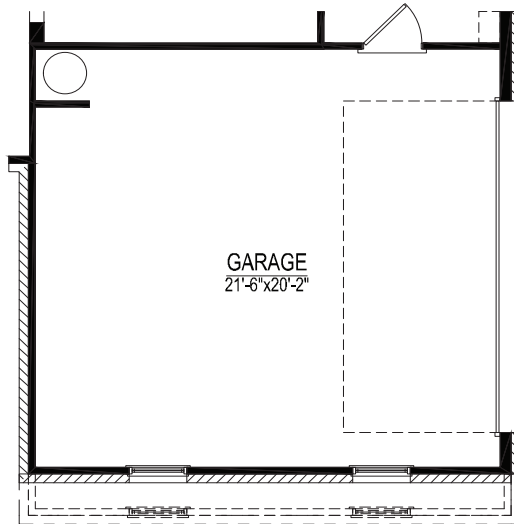

OPT. SIDE-LOAD GARAGE

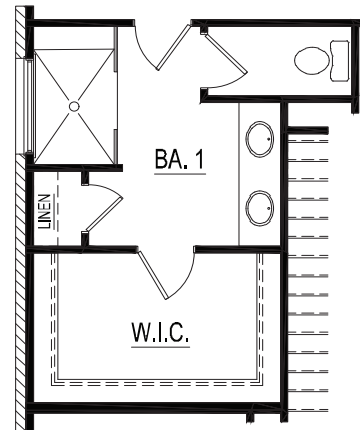

OPT. OWNER BATH



SIMPLY BUILT BETTER.

We are constantly improving our homes. Arden Homes reserves the right to revise and/or substitute Features, square footage, dimensions, specifications, architectural details, designs and pricing without notice.

Jordan Myrick
336-817-9305 | Jordan@theardengroup.com



COTTAGE HILL

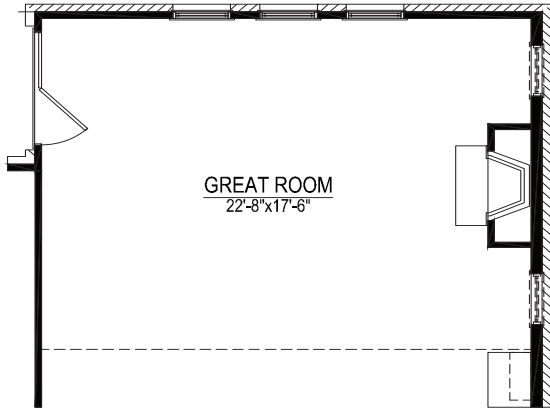

GREAT ROOM
22'-8" x 17'-6"

ALT. FIREPLACE LOCATION

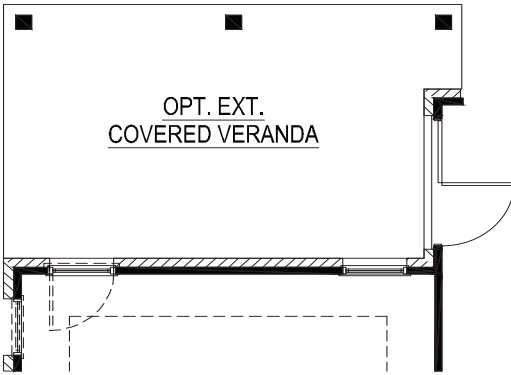

OPT. EXT.
COVERED VERANDA

OPT. EXT. VERANDA

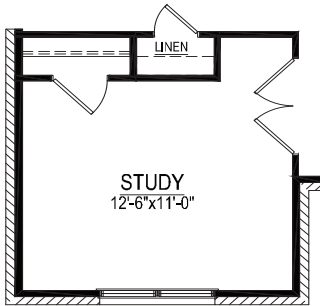

STUDY
12'-6" x 11'-0"

OPT. STUDY

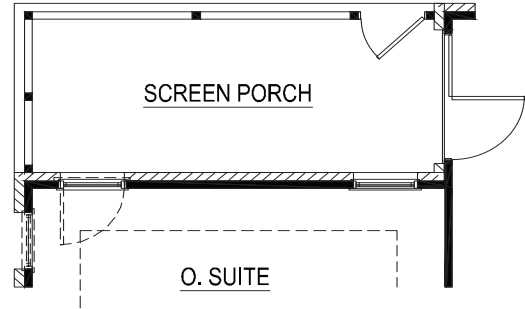

SCREEN PORCH

O. SUITE

OPT. SCREEN PORCH

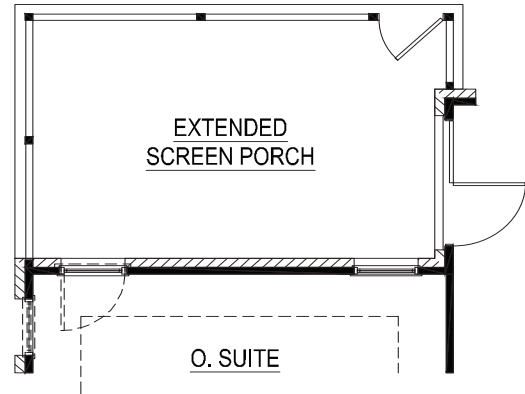

EXTENDED
SCREEN PORCH

O. SUITE

OPT. EXT. SCREEN PORCH

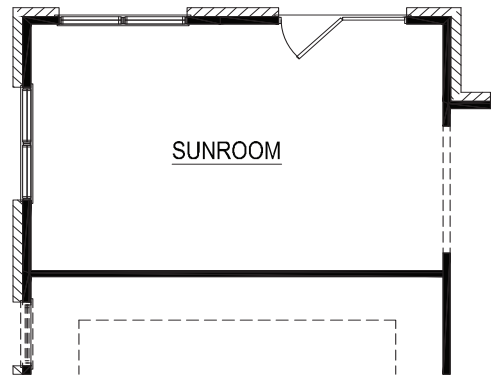

SUNROOM

OPT. SUNROOM
+211 SQFT.



SIMPLY BUILT BETTER.

We are constantly improving our homes. Arden Homes reserves the right to revise and/or substitute Features, square footage, dimensions, specifications, architectural details, designs and pricing without notice.

Jordan Myrick
336-817-9305 | Jordan@theardengroup.com

